

Two vibration sizes in one kit (Ø 28 + 38 mm)

Complete battery-powered concrete vibrator set for the rental industry includes two interchangeable vibrator heads and shafts (Ø28 mm & Ø38 mm) in one kit.

The PACLITE E-VIB offers a powerful and emission-free solution for concrete vibration on-site. Specially designed for rental applications, this complete set is delivered in a durable transport case and includes 2 Li-Ion batteries, a fast charger (110–230 V), and both Ø28 mm and Ø38 mm heads with flexible shafts.

FEATURES AND BENEFITS

- **All-in-one rental solution:** 2 vibrator heads and shafts (Ø28 & Ø38 mm) supplied in one complete set.
- **Zero emissions:** Ideal for floors and in confined spaces.
- **Robust and rental-ready:** Induction-hardened heads, reinforced shaft hose, and shock-resistant casing.
- **Low hand-arm vibration:** Operator comfort and safety during extended use.
- **Battery-powered freedom:** Each 6.0 (A) 20 V Li-Ion battery delivers up to 40 minutes of continuous runtime. Average fast charging time is just 45 minutes.

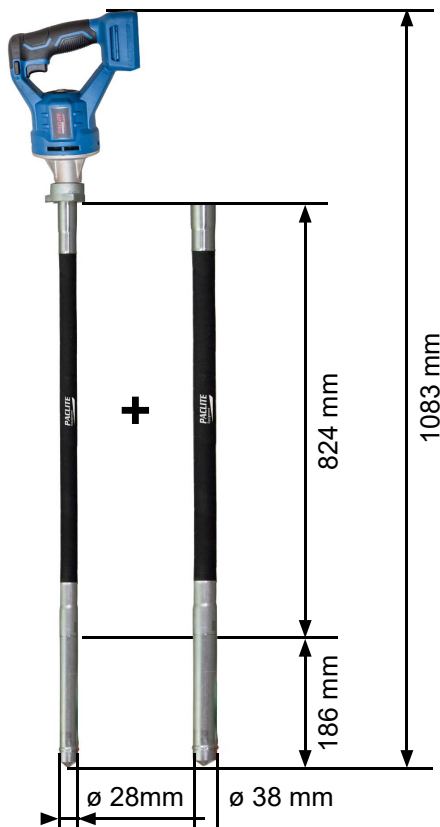

x 2 batteries B1840

| Code | E-28/E-38 ECO MAX |
|----------------------------|---|
| Model | E-VIB 28 & 38 mm |
| Type | Flexible |
| Voltage | 6.0 (A) 20 V Li-Ion battery 3-200 Hz |
| Frequency (Hz) | 200 |
| Dimensions L x W x h (mm) | 1083 x 93 x 250 |
| Head dimensions D x L (mm) | 38 x 186 |
| Weight (kg) | 4,2 |
| Total weight (kg) | 9,4 |
| Sound pressure (dB (A)) | 74 |

| Battery | E-30/20 V |
|---|----------------------|
| Chemical composition | Li-Ion battery |
| Battery capacity (Ah) | 6.0 |
| Average charging time (min) | 50-60 |
| Supplied batteries | x 2 - 20 Volt Li-ion |
| Compatible batteries | BL1830, BL1840 |
| Net weight EPTA (kg) | 3 |
| Hand-arm vibrations on 3 axes (m/s ²) | 3,6 |

* Measured according to ISO 5349

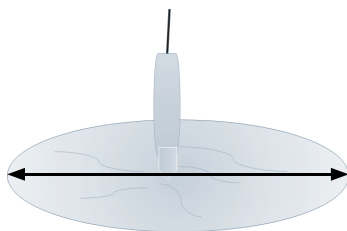

280-450 mm

The influence of Zone is determined by the diameter of vibrator head.

STANDARD ACCESSORIES

Transport case + 2 batteries
+ 1 battery charger



Battery charger C1860L